

MICEDD

DEEPWATER DEVELOPMENT

28 - 30 March 2023 | Millennium Gloucester Hotel | London, UK

ORGANIZED BY



Quest Offshore

World Oil[®]

OneSubsea Configurable Subsea Production Systems

Allowing standardization to co-exist with customization within the subsea space

Phillip Theriot, OneSubsea Trees, Wellhead and CCUS Product Champion

Ted Mercer, OneSubsea Manifold and Connection Systems Product Champion

Challenges of ETO Solutions



Schedule



**Return on
Investments**



Configurability



Sustainability

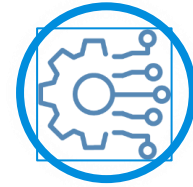

Adaptability

Evolution of product design approach

ETO XT Products

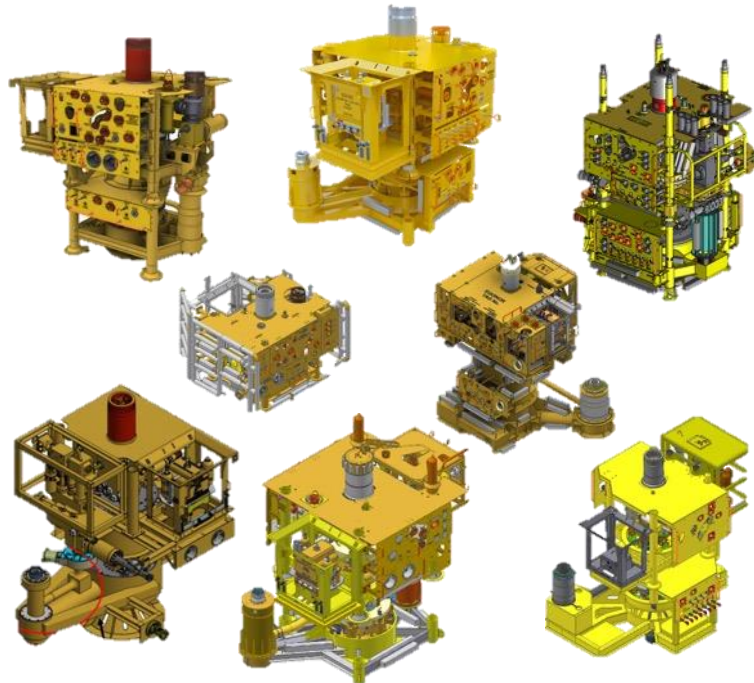

ETO Manifolds Products



Evolution of product design approach

CTO XT Platform

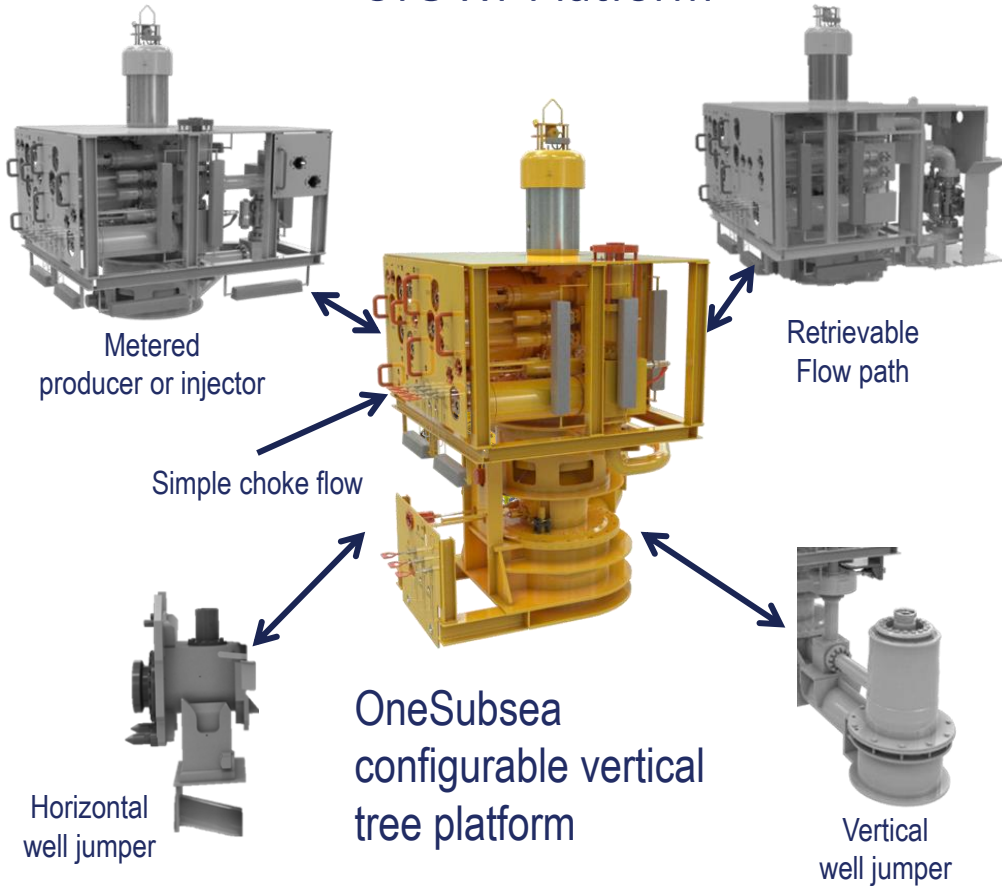

CTO Manifolds Platform

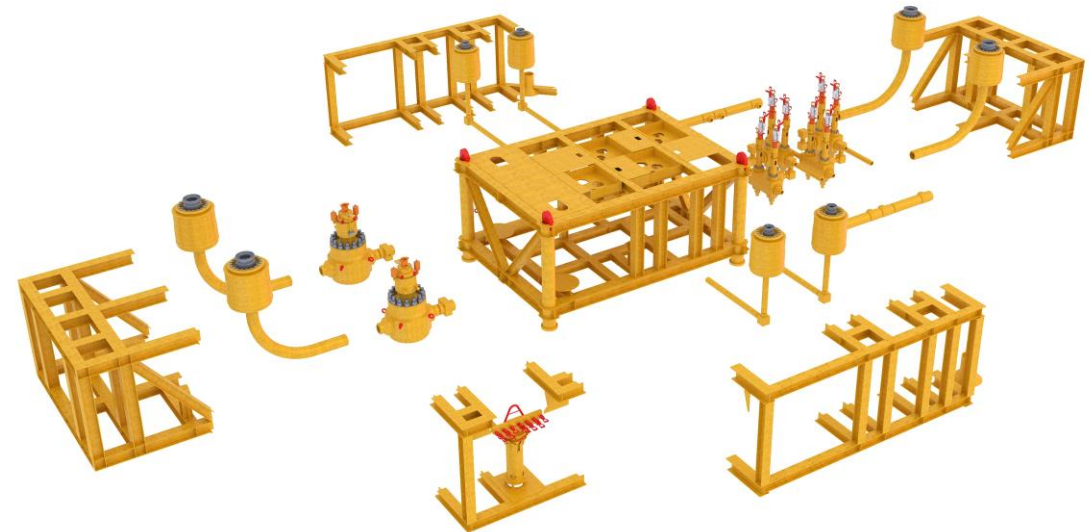

Configure To Order Portfolio

OneSubsea Configurable Solutions

Subsea Field Development Planning

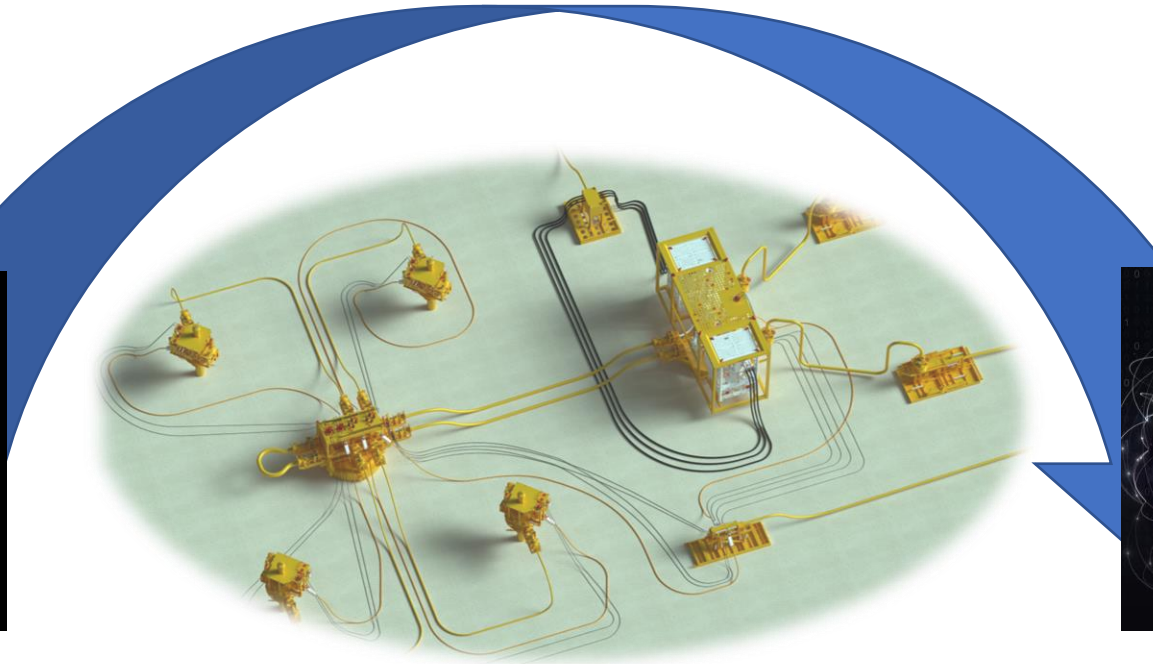
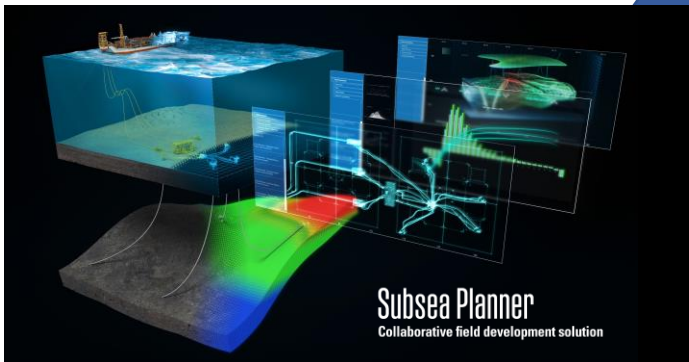

Services and Tooling



CTO Trees & Manifolds Platforms

- Efficiency through consistency in design and packaging
 - Consistent product architecture throughout levels of design complexity
 - Allowing standardization to coexist with customization
- Independent functional modules within tree package
 - Production Flowpath
 - Welljumper
 - Controls
 - ROV Access & Intervention
 - Valve & Actuation
- Installation & Drill-Center Flexibility
 - TH in WH
 - TH in THS

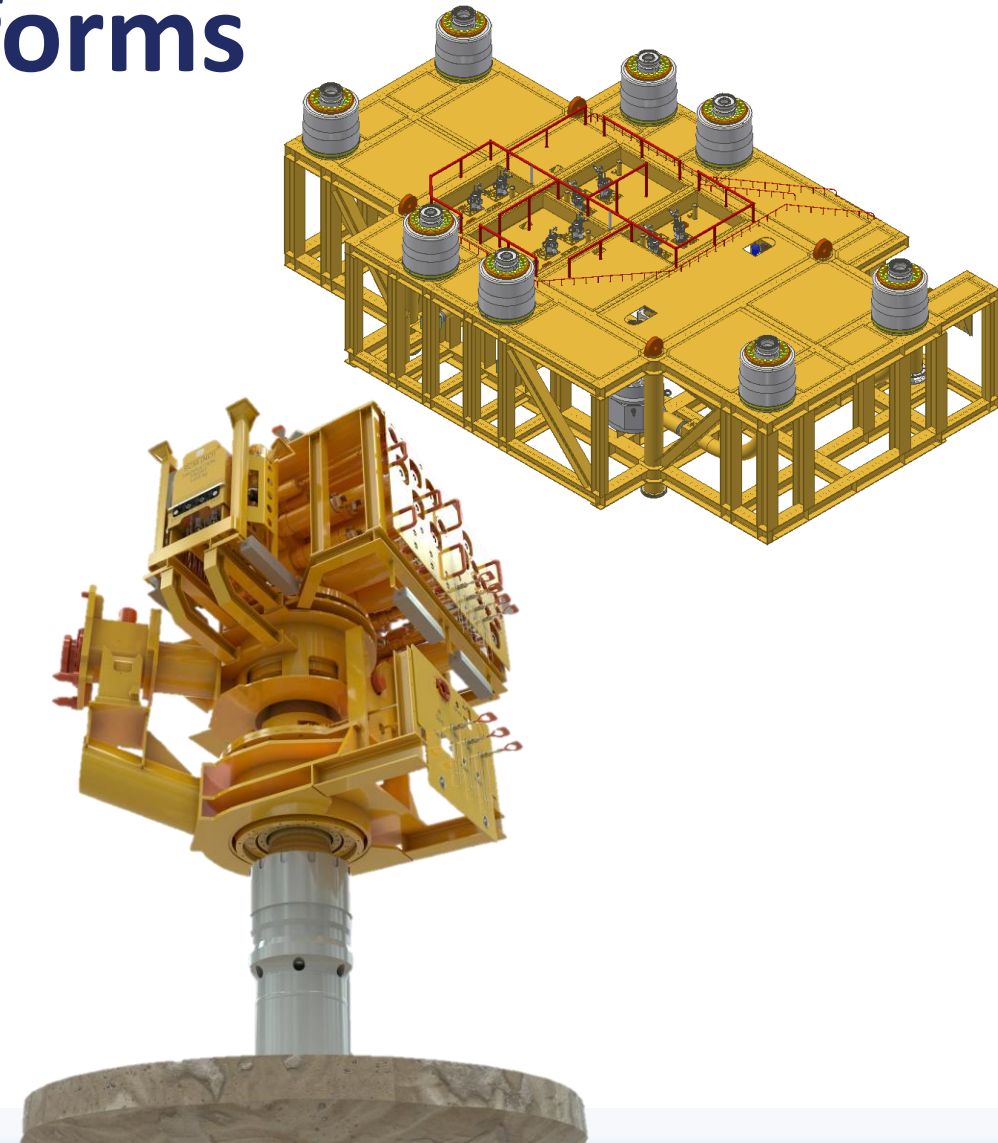

Configurable Vertical Tree Platform

Trees - welljumper

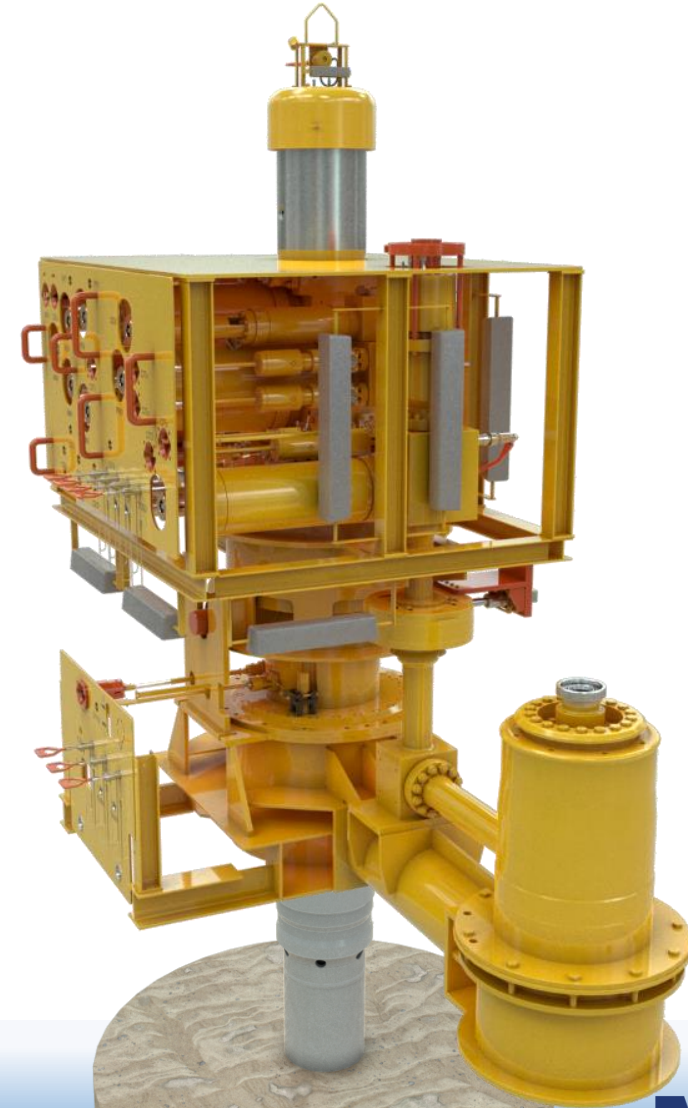

Configurable Vertical Tree Platform

Trees - welljumper

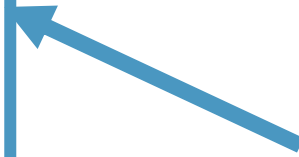

Configurable Vertical Tree Platform

Trees – wellhead interface



Configurable Vertical Tree Platform

Trees – wellhead interface



Configurable Vertical Tree Platform

Trees – wellhead interface



Configurable Vertical Tree Platform

Trees – flowpath configurability

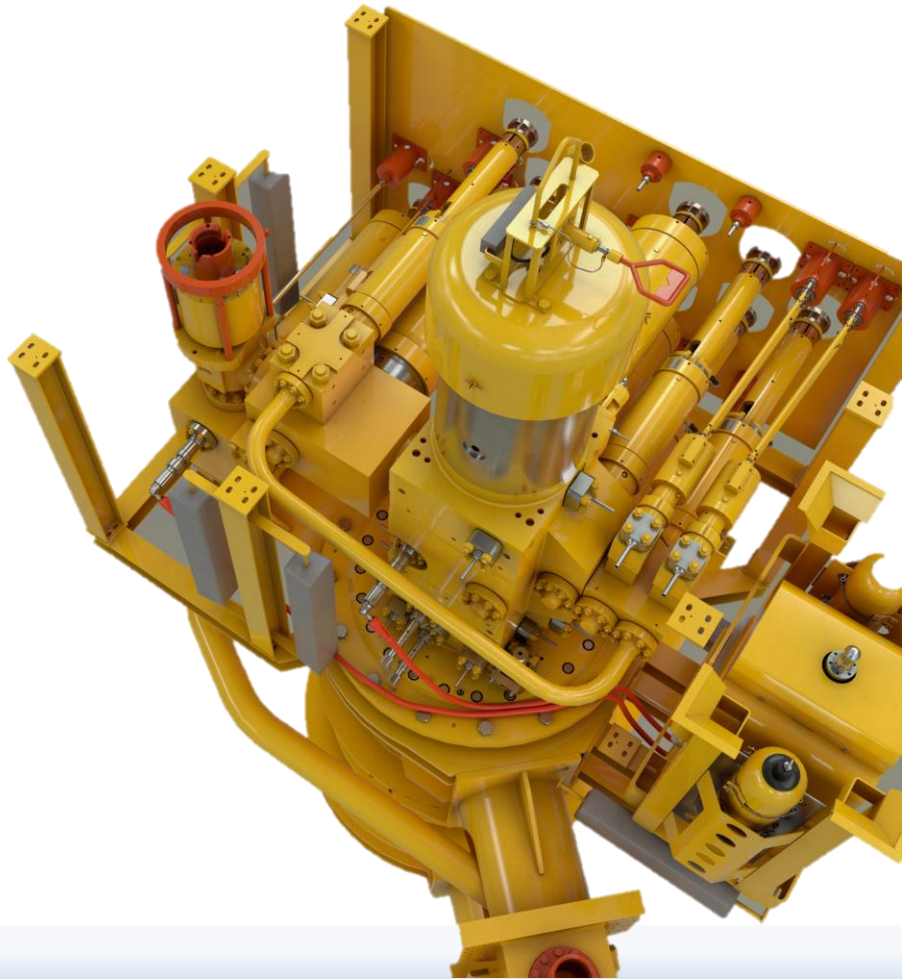

Configurable Vertical Tree Platform

Trees – flowpath configurability

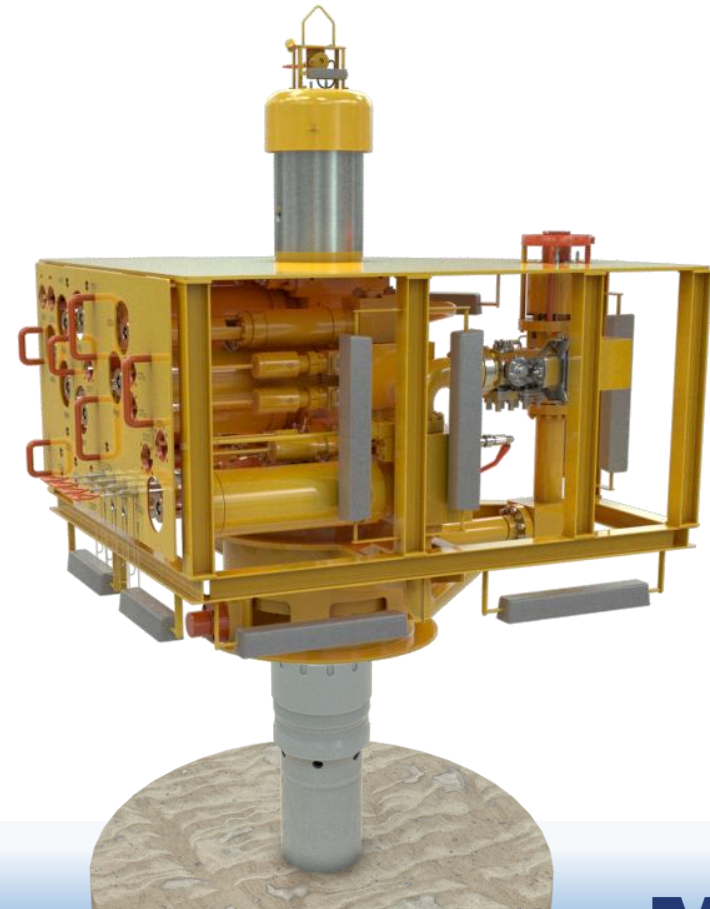

Configurable Vertical Tree Platform

Trees – flowpath configurability

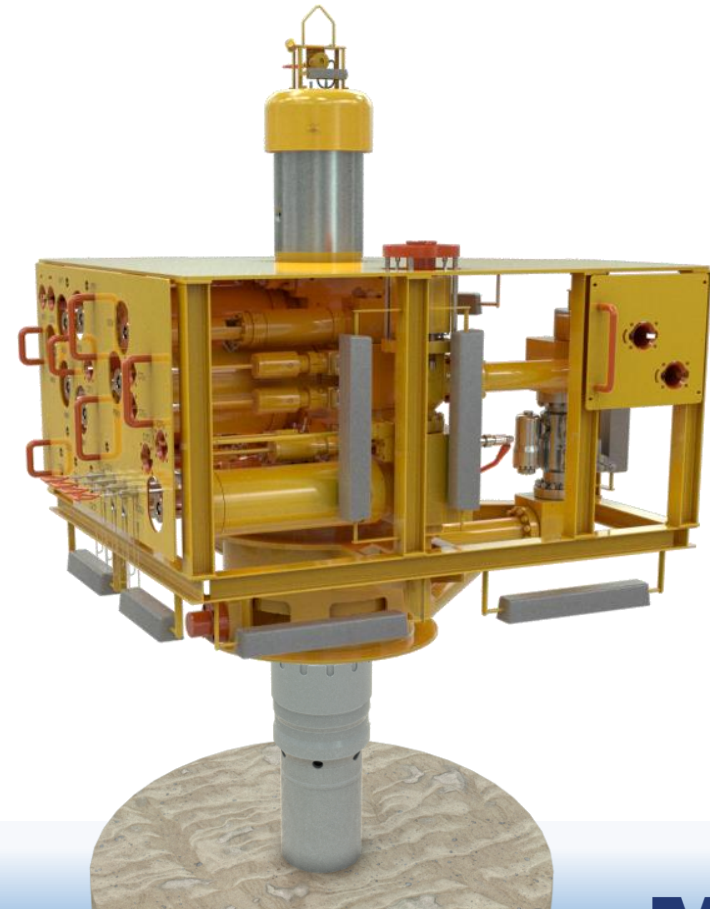
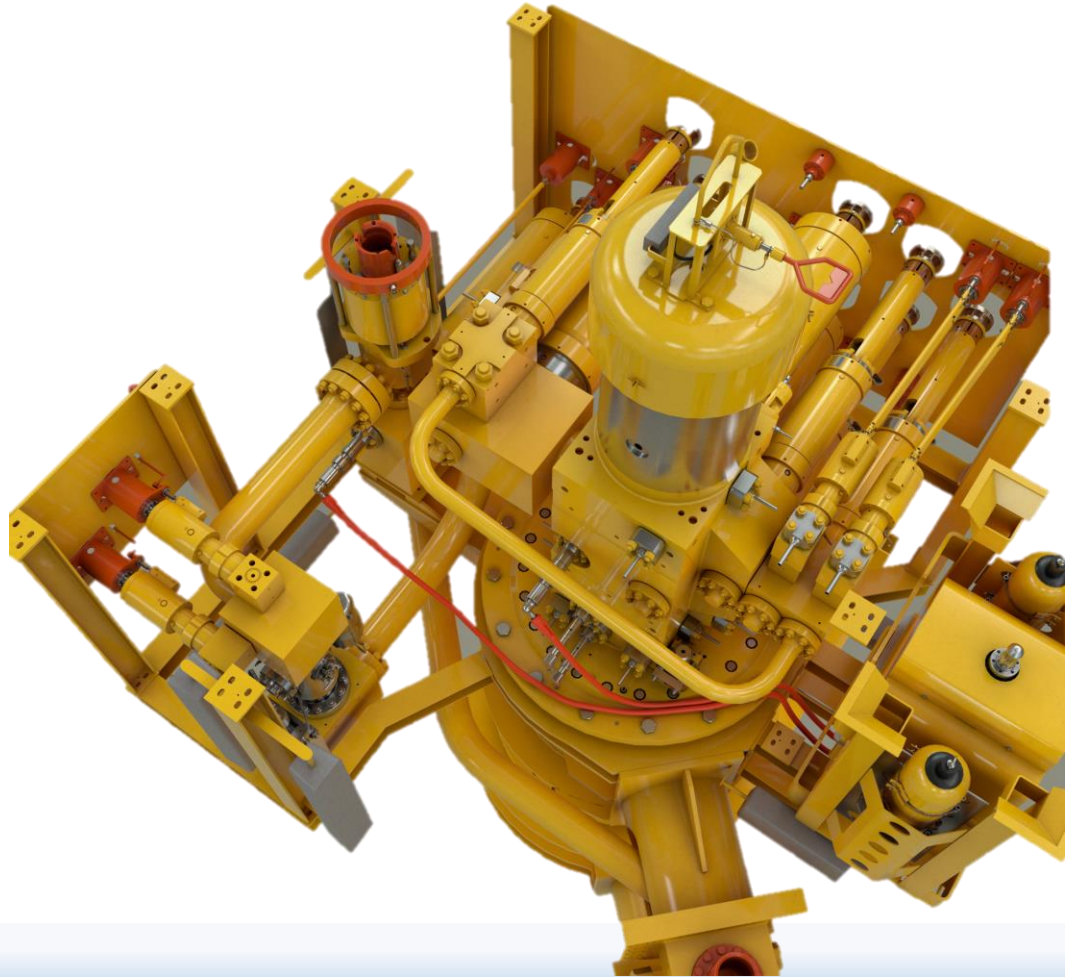

Configurable Vertical Tree Platform

Trees – flowpath configurability

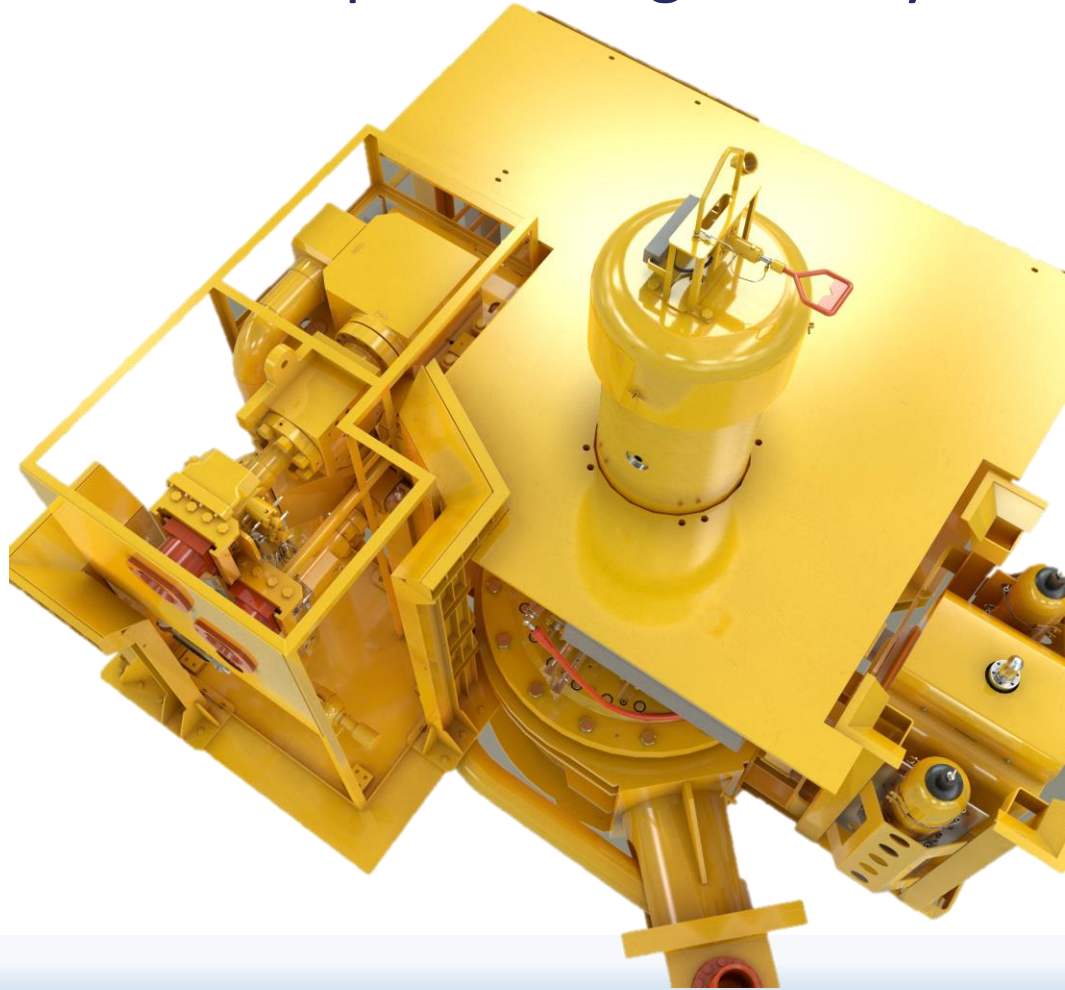

Common Service Tooling

Benefits

- Increased global availability
- Inherent sparing availability
- Forwards and backwards compatibility
- AES transition enabled
- Rental-Model TH in WH system, independent of rig-specific interfaces
- Reduced capex

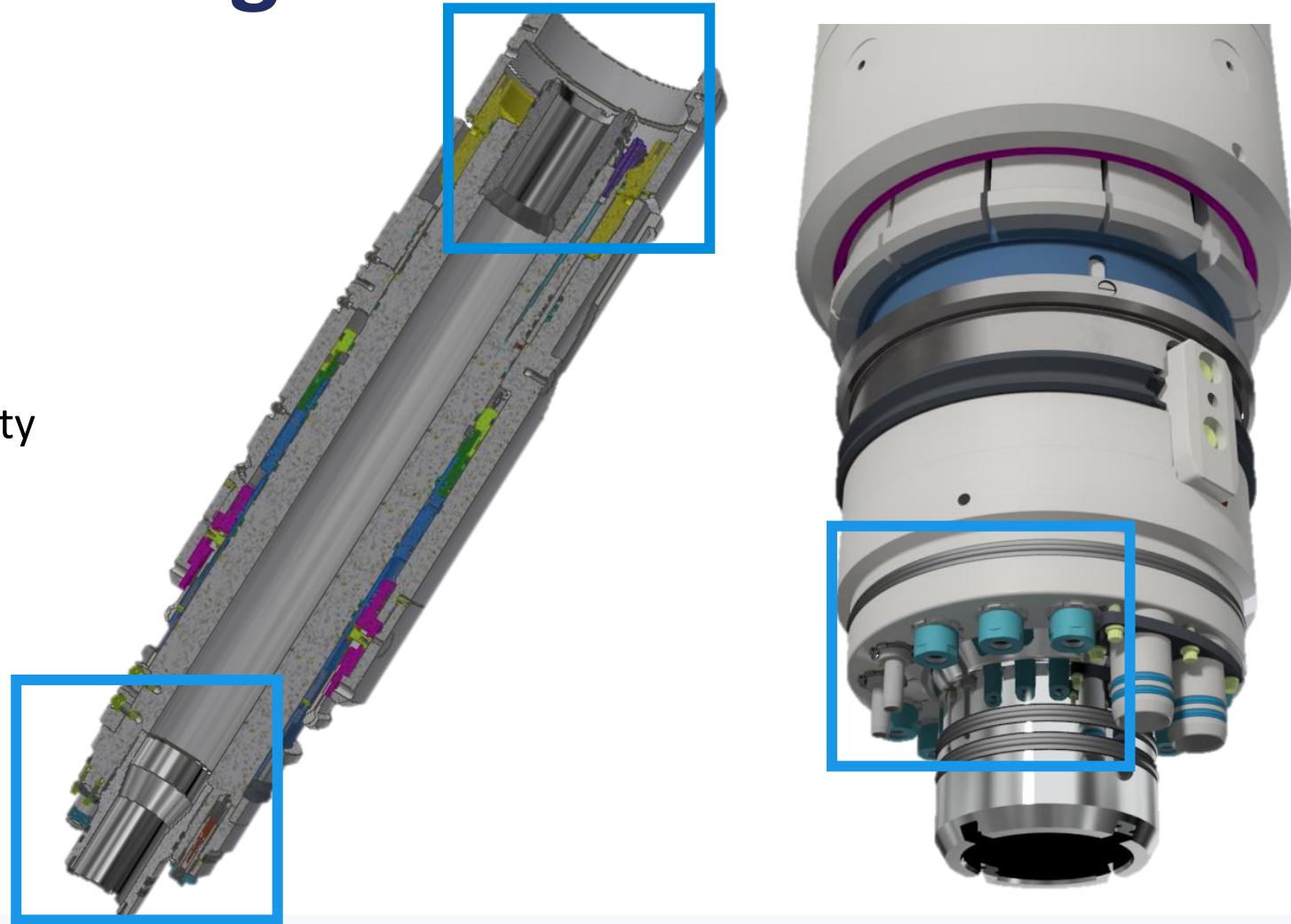

Configurable Platforms

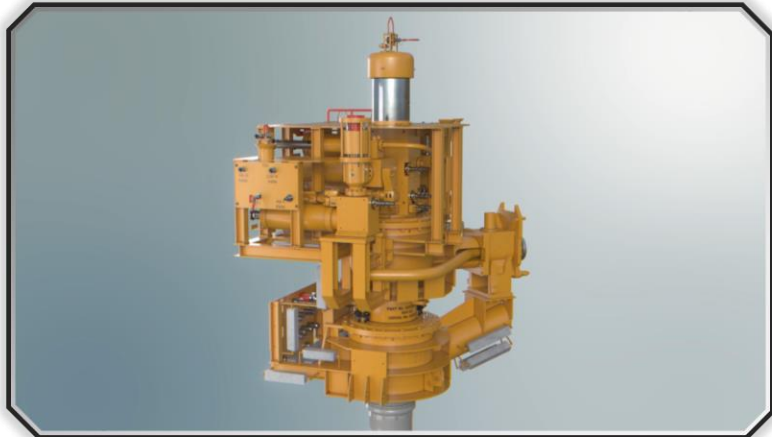

SPS Configure to Order Benefits

Schedule



Reliable delivery
with budget certainty

ROI



Bring ROI forward and
reduce total cost of ownership

Configurability



Adapt to dynamic field
conditions for the life of field

Adaptability



Relocate equipment quickly
to optimize global portfolio

Sustainability



Reduce emissions and
lessen environmental impact

**FAST TRACK
YOUR SUBSEA
SUCCESS**



Thank You



Phillip Theriot
Trees, Wellhead & CCUS Product Champion
PTheriot@slb.com
+1 337 298 9287

Contact us @



Ted Mercer
Manifold & Connection Systems Product Champion
TMercer@slb.com
+1 832 657 4468



MICEDD

DEEPWATER DEVELOPMENT

28 - 30 March 2023 | Millennium Gloucester Hotel | London, UK

ORGANIZED BY



Quest Offshore

World Oil®